

## Bending Force Chart (Tonnes / Meter Length)

▼ t	V ►	4	8	12	16	20	24	32	40	48	64	80	96	120	150	180	200	250	300	
H (min)		3	6	8.5	11.5	14.5	17	23	29	34	46	57	68	85	110	130	145	180	215	
R (min)		0.6	1.3	2	2.7	3.3	4	5.3	6.7	8	10.5	13.5	16	20	25	30	33	42	50	
0.5	4	2																		
1	19	8	5																	
1.5		19	12	8	7															
2		38	22	16	12	10														
2.5			37	26	20	17	12													
3			56	36	28	24	17	14	11											
4				74	56	44	32	25	20	16										
5						75	50	40	33	24	19									
6							77	57	48	35	27	23								
8								112	86	64	50	41	33							
10									150	100	80	60	51	43						
12										155	105	96	77	62	51					
15											180	150	120	96	80	72				
18												200	160	128	107	96	77			
20													250	200	170	150	120	100		
25														296	250	220	178	150		

For S.S.-U.T.S. 72 kg/mm<sup>2</sup>  
Multiply force by 1.6

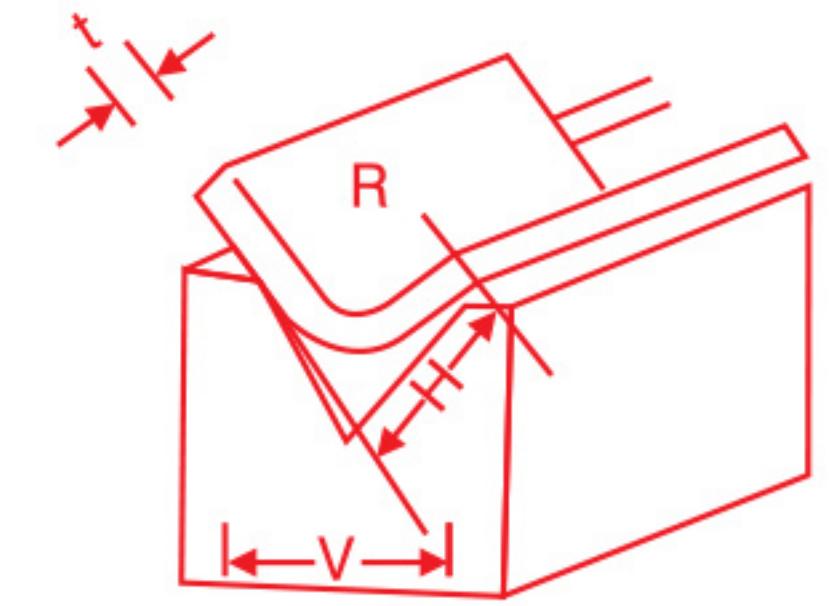

**The above chart is for reference only. For more detailed information please contact us.**